



**BAND-IT®**  
THE CLAMPING EXPERTS

**IDEX**  
IDEX CORPORATION

STAINLE

## Product & Application FAQ

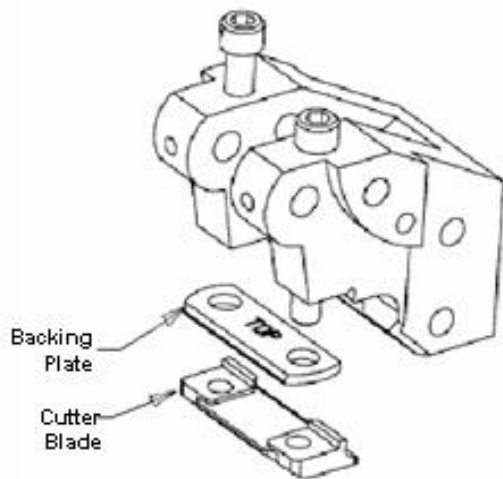

Hand polishing cutter blade with a fine stone.

*The World's Leader in Quality Engineered  
Band Clamping Systems.*

**BAND-IT-IDEX, Inc.**  
A Unit of IDEX Corporation

PO Box 16307  
Denver, CO 80216

Phone: (303) 320-4555  
Fax: (303) 333-6549

E-mail: [marketing.BAND-IT@idexcorp.com](mailto:marketing.BAND-IT@idexcorp.com)

### **Question: What causes BAND-IT® Jr. clamps to break during installation?**

#### **Answer:**

Clamps breaking during tensioning typically result because two important tool parts - the cutter blade and backing plate - are worn or have not been maintained per the tool instructions. Without proper maintenance, lost production, improperly tensioned hose assemblies and weakened clamp locks may result. A second cause of clamps breaking during tensioning is over tensioning - to be covered in a separate FAQ.

These problems and frustrations can be avoided with regular tool inspection and maintenance. To significantly reduce clamp installation problems, insure the bolts holding these parts are tight and the working surfaces have been honed to remove material buildup will significantly reduce clamp installation problems.

#### **Hints and Help:**

The cutter blades and backing plates are available from BAND-IT® as a kit, part number J93099. The parts are used on the following BAND-IT® tools.

##### Hand Tools:

- C00269
- J00169
- J05069

##### Air Tools:

- S75099
- S35099
- S10099 (not sold as new)
- J900 (not sold as new)

- A Cutter Blade Kit consists of the cutter blade, backing plate, and retaining bolts. These parts should always be replaced as a set regardless of the perceived life remaining on one or the other.
- Regular maintenance of these parts includes examination of the leading edge condition and wear of the Cutter Blade.
- Steel shavings and material buildup will result from normal day-to-day clamp installation. Shavings and foreign material should be removed from the cutter blade leading edge by hand polishing with a fine stone. Polish all points of contact with the clamp without altering the part's surface dimensions. A #2 India stone works well for this procedure.
- When installing new parts or after hand polishing existing parts, be sure to fully tension the retaining bolts to 10-14 Ft - Lbs. Always replace the cutter blade, backing plate, and the retaining bolts as a set. Continuous load and stress may alter or weaken the bolt threads. Periodically check the retaining bolts to insure adequate tension.

**For More Information or Instruction Manuals,  
Please Visit [www.BAND-IT-IDEX.com](http://www.BAND-IT-IDEX.com)**

FAQ-101  
Issued 06/05